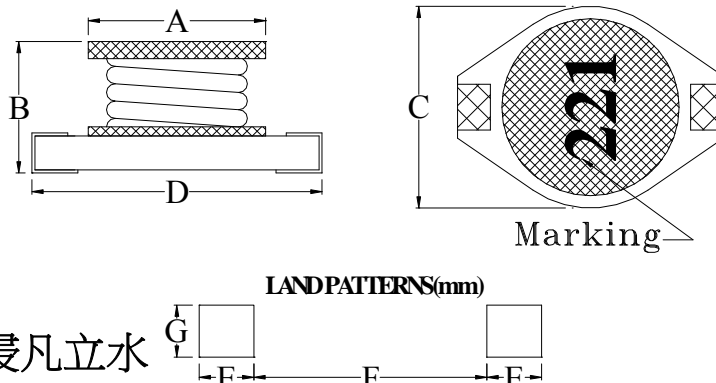

SPECIFICATION FOR APPROVAL

COMMODITY	SMD POWER COIL	SPEC NO.	SP-060802133
ITEM	JSPK 1306-221M Green	版本：A	表單編號：QRRD-01-02

(1) DIMENSION: (UNIT: mm)		DIM.	TOL.
	A	13.5	Max.
	B	7.5	Max.
	C	15.4	Max.
	D	18.54	Max.
	E	2.92	REF.
	F	12.45	REF.
	G	2.79	REF.

(2) ELECTRICAL CHARACTERISTIC	TEST INSTRUMENTS.
INDUCTANCE	220 ± 20% μH
TEST FREQUENCY	100 KHz
TEST VOLT	0.1 V
RDC	380 (max) mΩ
Isat	2.4 (max) A
Irms	1.2 (max) A

AGILENT 4294A Precision Impedance Analyzer.
 AGILENT 4285A Precision L.C.R. Meter.
 HP-4286A RF L.C.R. Meter.
 ZENTECH 3302 Automatic Components Analyzer.
 ZENTECH 101 L.C.R. Meter.
 WAYNE KERR 6420 Precision Impedance Analyzer.
 ZENTECH 1320 BIAS CURRENT.
 ZENTECH 502AC Resistance Merter.
 ADEX AX-1155B DC Low Ohm Meter.

REMARK :

1. Inductance drop = 10% typ. at Isat.
2. ΔT = 40°C typ. at Irms.

PURCHASER CONFIRMED	APPROVED	CHECKED	DRAWN
			