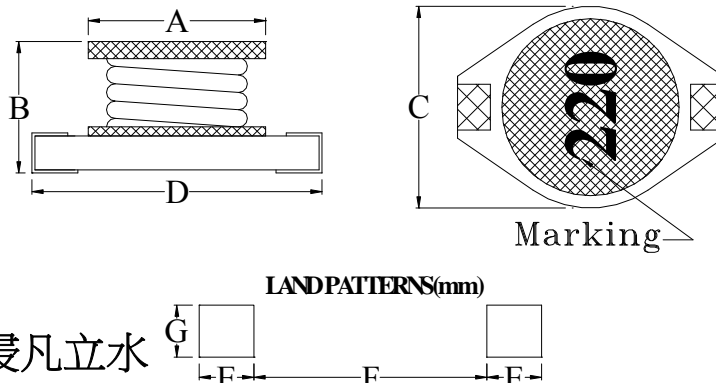

SPECIFICATION FOR APPROVAL

COMMODITY	SMD POWER COIL	SPEC NO.	SP-060802132
ITEM	JSPK 1306-220M Green	版本：A	表單編號：QRRD-01-02

(1) DIMENSION: (UNIT: mm)		DIM.	TOL.
 <p>含浸凡立水</p> <p>LANDPATTERNS(mm)</p>	A	13.5	Max.
	B	7.5	Max.
	C	15.4	Max.
	D	18.54	Max.
	E	2.92	REF.
	F	12.45	REF.
	G	2.79	REF.

(2) ELECTRICAL CHARACTERISTIC	TEST INSTRUMENTS.
INDUCTANCE	22 ± 20% μH
TEST FREQUENCY	100 KHz
TEST VOLT	0.1 V
RDC	47 (max) mΩ
Isat	7.0 (max) A
Irms	3.5 (max) A

AGILENT 4294A Precision Impedance Analyzer.
 AGILENT 4285A Precision L.C.R. Meter.
 HP-4286A RF L.C.R. Meter.
 ZENTECH 3302 Automatic Components Analyzer.
 ZENTECH 101 L.C.R. Meter.
 WAYNE KERR 6420 Precision Impedance Analyzer.
 ZENTECH 1320 BIAS CURRENT.
 ZENTECH 502AC Resistance Merter.
 ADEX AX-1155B DC Low Ohm Meter.

REMARK :

1. Inductance drop = 10% typ.at Isat.

2. ΔT = 40°C typ.at Irms.

PURCHASER CONFIRMED	APPROVED	CHECKED	DRAWN
			