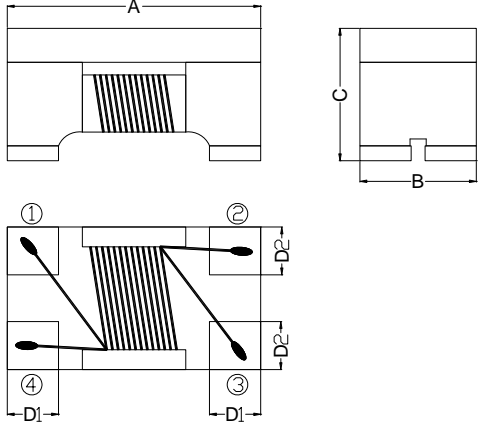

SPECIFICATION FOR APPROVAL

COMMODITY	COMMON MODE CHOKE	SPEC NO.	SP-0210302005
ITEM	JPWC 1812-601/2.5 Green	版本：A	表單編號：QR-012-02

(1) DIMENSION: (UNIT: mm)		DIM.	TOL.	
	A	4.50	±0.20	
	B	3.20	±0.20	
	C	2.80	±0.20	
	D1	0.90	±0.15	
	D2	1.05	±0.15	

(2) ELECTRICAL CHARACTERISTIC	TEST INSTRUMENTS.	
IMPEDANCE	450 (min) Ω 600 (typ.) Ω	<input checked="" type="checkbox"/> AGILENT 4294A Precision Impedance Analyzer. <input type="checkbox"/> AGILENT 4285A Precision L.C.R. Meter. <input type="checkbox"/> HP-4286A RF L.C.R. Meter.
TEST FREQUENCY	100 MHz	<input checked="" type="checkbox"/> ZENTECH 3302 Automatic Components Analyzer. <input type="checkbox"/> ZENTECH 101 L.C.R. Meter.
DC RESISTANCE	0.06 (max) Ω	<input type="checkbox"/> WAYNE KERR 6420 Precision Impedance Analyzer. <input checked="" type="checkbox"/> ZENTECH 1320 BIAS CURRENT.
RATED CURRENT	2500 (max) mA	<input checked="" type="checkbox"/> ZENTECH 502AC Resistance Merter. <input type="checkbox"/> ADEX AX-1155B DC Low Ohm Meter.
RATED VOLT.	50 (max) Vdc	
WITHSTAND VOLT.	125 (max) Vdc	
IR	10 (min) MΩ	

REMARK :

1. Operating temperature range : - 40°C to + 125°C (Including self temp. rise)
2. Storage temperature range : - 40°C to + 125°C (on board)

PURCHASER CONFIRMED	APPROVED	CHECKED	DRAWN
			

TEST REPORT

SPEC NO : SP-0210302005

Typical Impedance v.s. Frequency Curve

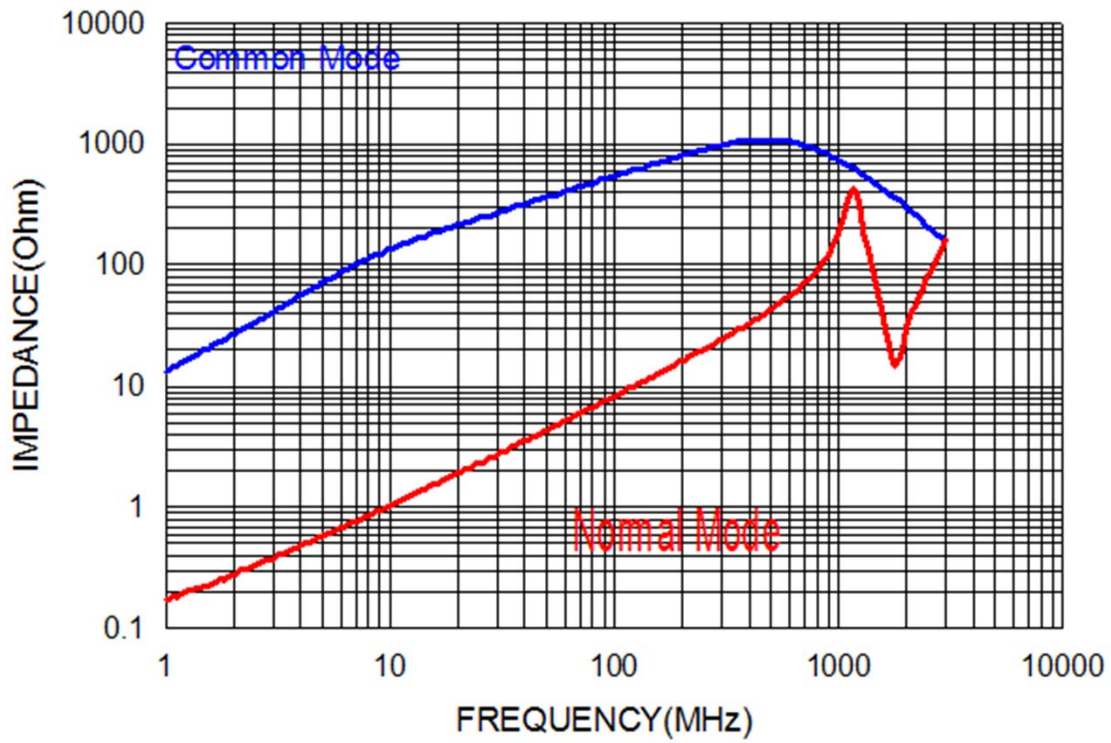

Check by :



Test by :



TEL : 886-2-2689-4971 FAX : 886-2-2689-4260
E-mail : jantek@jantek-elec.com.tw
Web-Site : www.jantek-elec.com.tw