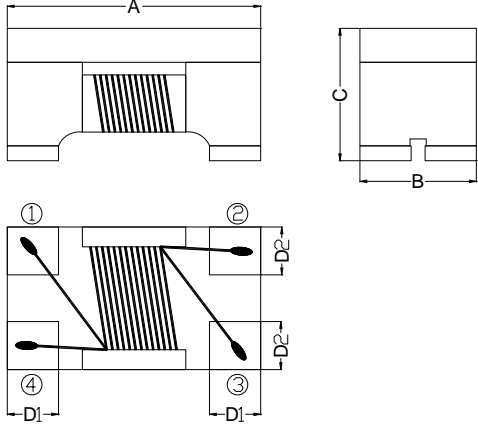

# SPECIFICATION FOR APPROVAL

COMMODITY	<b>COMMON MODE CHOKE</b>	SPEC NO.	SP-0210310002
ITEM	<b>JPWC 1812-801/1</b>	Green	版本：A 表單編號：QR-012-02

(1) DIMENSION: (UNIT: mm)		DIM.	TOL.	
	A	4.50	±0.20	
	B	3.20	±0.20	
	C	2.80	±0.20	
	D1	1.00	±0.10	
	D2	1.20	±0.10	

(2) ELECTRICAL CHARACTERISTIC			TEST INSTRUMENTS.
IMPEDANCE	800 ± 25%	Ω	<input checked="" type="checkbox"/> AGILENT 4294A Precision Impedance Analyzer.
TEST FREQUENCY	100	MHz	<input type="checkbox"/> AGILENT 4285A Precision L.C.R. Meter. <input type="checkbox"/> HP-4286A RF L.C.R. Meter.
DC RESISTANCE	0.24 (max)	Ω	<input checked="" type="checkbox"/> ZENTECH 3302 Automatic Components Analyzer.
RATED CURRENT	1000 (max)	mA	<input type="checkbox"/> ZENTECH 101 L.C.R. Meter. <input type="checkbox"/> WAYNE KERR 6420 Precision Impedance Analyzer.
RATED VOLT.	50 (max)	Vdc	<input checked="" type="checkbox"/> ZENTECH 1320 BIAS CURRENT.
WITHSTAND VOLT.	125 (max)	Vdc	<input checked="" type="checkbox"/> ZENTECH 502AC Resistance Merter. <input type="checkbox"/> ADEX AX-1155B DC Low Ohm Meter.
IR	10 (min)	MΩ	

REMARK :

1. Operating temperature range : - 40°C to + 125°C (Including self temp. rise)
2. Storage temperature range : - 40°C to + 125°C (on board)

PURCHASER CONFIRMED	APPROVED	CHECKED	DRAWN
			

# TEST REPORT

SPEC NO : SP-0210310002

Typical Impedance v.s. Frequency Curve

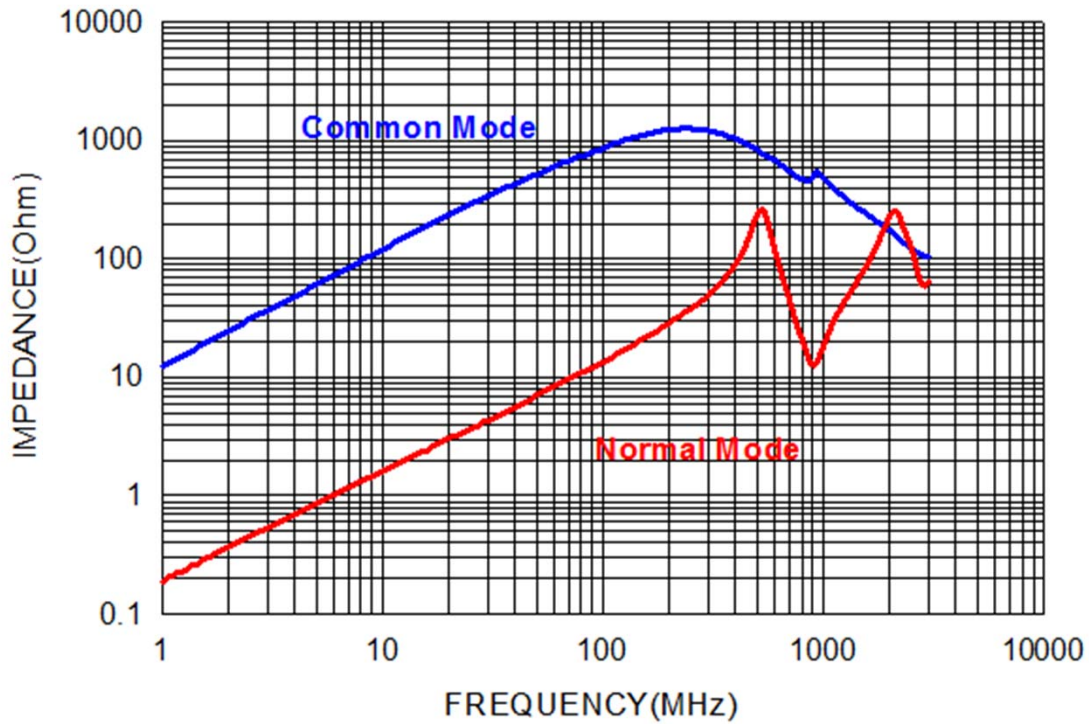

Check by :



Test by :



TEL : 886-2-2689-4971 FAX : 886-2-2689-4260  
E-mail : jantek@jantek-elec.com.tw  
Web-Site : www.jantek-elec.com.tw